

# 500W Pulse laser cleaning machine user manual



**Shenzhen Scotle Technology Group Limited**

No.14, 2F, Building Y1, Bantian Street Creative Park, Longgang District, Shenzhen, Guangdong, 518129  
China

[www.scotle.com](http://www.scotle.com)

## Foreword

Welcome to use the handheld laser cleaning products produced by Shenzhen Scotle Technology Group Ltd. For better use and maintain your laser equipment, please read this manual carefully before using this product. All laser operators must use personal protective equipment when using our laser machines. To avoid the hazards caused by lasers, please strictly follow all warnings and safety tips in this manual to prevent unnecessary risks. Our laser machines are safe and reliable by following this manual and applying reliable laser safety measures.

If the user has any comments and suggestions during use, please feel free to give us your advice to help us continue to revise and improve. Thank you again for using the products of Shenzhen Scotle Technology Group Ltd.!

During the operation, maintenance and service of this equipment, in order to ensure the safety of the operator, please do not disassemble the equipment privately. This product has no parts, components and assemblies that the user needs to repair by himself. Our company will not provide warranty service for damage to the equipment or accessories caused by the laser dismantled privately.

Our company certifies that this laser machine has been thoroughly tested and inspected. The inspection before shipment meets the published specifications. When you receive the machine, please check whether the packaging and parts are damaged. If so, it may have occurred during transportation. If the damage is obvious, please keep evidence and contact Shenzhen Scotle Technology Group Ltd.



## Contents

1. Safety Tips .....	4
1.1 Safety Level .....	4
1.2 Safety Range .....	5
1.2.1 Radiation Hazards .....	5
1.2.2 Skin Hazards .....	5
1.2.3 Fire Hazards .....	5
1.2.4 Smoke Hazards .....	5
1.3 Safety Signs .....	5
1.4 Reference Standards .....	7
2. Product Introduction .....	7
2.1 Principle .....	7
2.2 Application .....	7
2.3 The difference between single-mode Gaussian light beam and multi-mode flat-top light beam .....	8
2.4 Machine Structure .....	10
2.5 Packing List .....	13
3. Technical Parameters .....	14
4. Operation Steps .....	14
4.1 Unpacking Inspection .....	14
4.2 Machine Installation .....	15
4.3 Power On .....	16
4.4 Parameter Settings .....	17
4.5 End Operation .....	20
5. Maintenance .....	21
6. Troubleshooting and Solutions .....	22
7. After-sales Statement .....	22

## 1. Safety Tips

### 1.1 Safety Level

The laser level of this machine is class 4. **The NOHD distance is 20M.** To ensure the safety of the user, please make sure that the following measures have been taken before using the machine:

- ① When using this machine, please use a suitable grounded power supply and corresponding voltage.
  - ② Before operation, please wear special fiber laser protective glasses and gloves, **the glasses should suitable for wavelength range  $1070 \pm 20\text{nm}$  and conform to OD6+ standard;** do not look directly at the laser to avoid damage to the eyes or skin.
  - ③ Before emitting the laser, the dust-proof cover of the field lens needs to be removed;
  - ④ Make sure that all optical components are below eye level, and pay special attention to the height of the eyes when sitting on a chair.
  - ⑤ Avoid operating this machine in a dark, humid, hot, and unventilated environment.
  - ⑥ When storing and using the welding system, please avoid the influence of magnetic field, static electricity, electromagnetic radiation and strong power supply.
  - ⑦ Static electricity is likely to damage the precision electronic components on the circuit board. Please use anti-static packaging bags to store relevant external control cards. During installation, please wear well-grounded anti-static protective gloves or wrist strap.
  - ⑧ During installation, the signal line and power line of the system must be routed at a sufficient distance from the high-voltage cable and servo power cable of other systems.
  - ⑨ The shielding layer of signal line and power line of the system must be well grounded to avoid interference of signal line and power line.
  - ⑩ Before using the equipment system, please ensure that there are no flammable and explosive substances within 10 meters of the surrounding area. Please drive away irrelevant personnel within 10 meters of the surrounding area. The user must be trained by the manufacturer before operating the equipment.
  - ⑪ Please ensure that the system is stored in the environment of  $-20\text{ }^{\circ}\text{C}$  to  $+60\text{ }^{\circ}\text{C}$ , and the normal working environment temperature is  $25\text{ }^{\circ}\text{C} \pm 10\text{ }^{\circ}\text{C}$ .
  - ⑫ Make sure to operate the machine only after receiving safety training.
  - ⑬ Keep the machine clean, maintain the machine regularly to prevent foreign matter from entering the cavity, otherwise it will cause functional contamination and functional impact of related parts;
- For technical support, please contact the corresponding after-sales service department:

eBay after-sales:

AliExpress after-sales:

Amazon after-sales:

B2B and official website after-sales: [sales10@scotle.com](mailto:sales10@scotle.com)

# Warning! Warning! Warning!

**Make sure that the surrounding environment is free of flammable and explosive materials and other people before lighting up!**

## 1.2 Safety Range

### 1.2.1 Radiation Hazards

**Caution - Use of controls or adjustments or performance of procedures other than those specified herein may result in hazardous radiation exposure.** The laser cleaning process will generate visible and invisible radiation. **The level of laser radiation emitted through the laser aperture exceeds Class 1.** The high-energy laser beam of the pulse laser cleaning machine directly irradiates the human body, especially the eyes and skin, which may cause serious damage on eye includes retinal burns. To prevent these injuries, **special laser protection glasses suitable for wavelength range  $1070 \pm 20\text{nm}$  and conform to OD6+ standard** must be worn, the safety barriers and warning signs must be set up in the operating area.

### 1.2.2 Skin Hazards

Exposure to infrared and ultraviolet radiation during laser cleaning can hurt the skin. Laser sparks can also cause burns. Laser processing can transfer a lot of energy into the parts to be cleaned, so the parts will be very hot even after cleaning. It is necessary to take precautions to prevent skin damage by wearing protective clothing such as flame-resistant gloves, hats, leather aprons, and other flame-resistant clothing, sleeves and collars should be buttoned too.

### 1.2.3 Fire Hazards







If flammable or combustible materials are close to the laser work area, the heat and sparks generated during the work process may cause a fire or explosion. Laser cleaning work can only be carried out when there are no flammable materials in the area. Fire extinguishers should be located nearby, easily accessible, and have personnel trained in their use.

### 1.2.4 Smoke Hazards

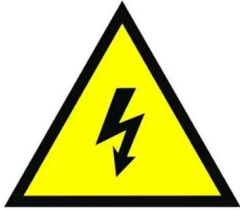
Laser cleaning "fumes" can consist of very fine particles and gases. Fumes and gases come from a combination of laser cleaning materials or shielding gases, paints, coatings, chemical reactions, and air pollutants. These fumes can adversely affect the lungs, heart, kidneys, and central nervous system. So better use this product in a ventilated environment and use a fume extraction system if necessary.

## 1.3 Safety Signs

As shown in the following table, all safety warning signs during the operation of the handheld laser cleaning machine (not limited to the signs on the laser body) include:

Safety signs	Name	Safety signs	Name	Safety signs	Name
	Electrical Hazards		Grounding mark		Laser radiation hazard
	Explanatory label (an example label of 1500W)		Alternative label for laser aperture		Class 4 Laser alternative label

Nameplate information (a sample nameplate of JPT 500W 220V pulse cleaning machine as follow):

<b>huizhoushiyunshengshukongshebeiyouxiangongsi</b>	
<b>JPT 500W Pulse Cleaning Machine</b>	
<b>Product name: 500W Pulse Cleaning Machine</b>	
<b>Model NO: JPT500</b>	
<b>Rating Voltage : 200~240V</b>	<b>Rating Frequency: 50Hz</b>
<b>Laser Power:500W</b>	<b>Rating Power:2000W</b>
<b>Phase:L+N+PE</b>	<b>Level: Class 4</b>
<b>Origin:China</b>	<b>Mfg year : 2025 . 02</b>
<b>Address :</b>	
<b>huizhoushihuiyangquqiuchangjiedaoxihucunweipangtianhaichuangxinke jiyuanAdong5lou 512200 China</b>	

## 1.4 Reference Standards

This product complies with EU harmonized legislation and complies with the above directives and standards only when installed in accordance with the manufacturer's specifications. European Community requirements for product safety

2006/42/EC Machinery (MD)

This directive requires laser equipment to comply with the following standards:

EN ISO 12100:2010

EN 60204-1:2018

EN ISO 11553-1:2020/A11:2020

EN ISO 11553-2:2008

EN 60825-1:2014/A11:2021

CDRH 21 CFR 1040.10

## 2. Product Introduction

### 2.1 Principle

The pulse laser cleaning machine uses high-energy laser pulses to irradiate the surface of the object, causing the surface dirt to quickly expand, vaporize or reach the ignition point due to heat. In this process, the laser energy is absorbed by the dirt layer, generating instantaneous high temperature and high pressure, causing the dirt layer to quickly break and fall off. Due to the short pulse characteristics and high energy density of the laser pulse, the cleaning process has very little thermal impact on the object substrate, avoiding the thermal damage that may be caused by traditional cleaning methods.

### 2.2 Application

Since pulse cleaning machines can clean a variety of materials, including metals, plastics, ceramics, glass, fiber composites, electronic components, stone, etc. That makes pulse laser cleaning machines are widely used in many fields, mainly including industrial manufacturing, cultural relics protection, automotive industry, aerospace and other fields.

#### **Industrial Manufacturing**

In industrial manufacturing, pulsed laser cleaning technology can be used for processing metal surfaces and remove pollutants. It is environmentally friendly and no direct contact required, so it is suitable for the production of high-precision products. Compared with traditional chemical methods, laser cleaning reduces secondary pollution and improves production efficiency and quality.

#### **Cultural Relics Protection**

In cultural relics protection, pulsed laser cleaning technology can remove dirt on the surface of cultural relics

without damaging the texture of cultural relics, so it is widely used in the cleaning works of museums and historical sites. This technology is particularly suitable for cleaning scenes of historical buildings and artworks.

### **Automotive Industry**

In the automotive industry, pulsed laser cleaning equipment is used to treat the surfaces of various parts, such as rust removal, degreasing, etc. This technology not only improves efficiency, but also ensures the integrity and quality of parts.

### **Aerospace**

Due to the high precision and high quality requirements of aerospace materials, traditional processing methods cannot meet the needs of cleaning. Pulse laser cleaning technology solves this problem and can be used for the maintenance of aircraft engine components, etc., ensuring high-precision cleaning effects.

### **Other application areas**

In addition, pulse laser cleaning technology can also be applied to areas such as building stone renovation, disinfection and cleaning of medical equipment. Its high efficiency and environmental protection characteristics make this technology widely used in these fields.

## **2.3 The difference between single-mode Gaussian light beam and multi-mode flat-top light beam**

Theoretically, the single-mode and multi-mode of lasers refer to the mode type of laser beam propagation, its propagation mode can be a single mode or a mixture of multiple modes. In a single-mode laser, there is only one beam propagation mode, so the beam diameter and beam energy distributions are in Gaussian. In contrast, a multi-mode laser supports multiple propagation modes at the same time, so the beam diameter and energy distribution appear as a superposition of multiple wave packets, and its beam is similar to a flat-top light.

In the application of laser cleaning, the difference between Gaussian light and flat top light is very important, especially when facing precision workpieces, you must understand the cleaning requirements first and then choose the laser. So what is Gaussian light? Gaussian light is similar to normally distributed light, its laser energy in the middle is strong but weak at the edge, and the spot distribution is uneven. The advantage of this spot is that the energy is concentrated and the transmission is farther. The disadvantage is easy to damage the base material. Flat top light is named relative to Gaussian light. Its spot distribution is more uniform. When facing precision instruments, it can perfectly remove pollutants without damaging the base material.

# Gauss Light VS Flat top light

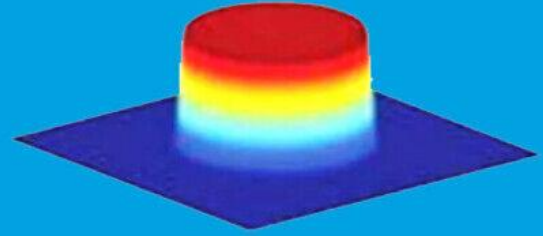
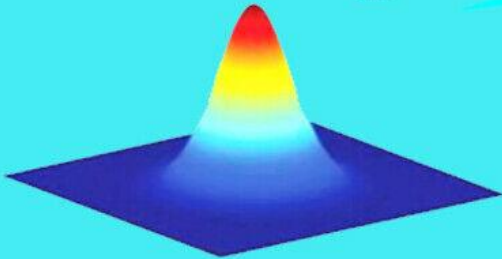

High frequency



High beam quality



High energy density



Wide spot



Great energy



Flat-top beam

## Applicable Scenarios

- ★ Strong adhesion
- ★ Difficult to remove
- ★ Deep corrosion
- ★ Oxidized layer
- ★ Thick paint, etc

## Applicable Scenarios

- ★ Light adhesion
- ★ Easy to remove
- ★ Yellow rust
- ★ Oil, gray
- ★ Paint removal
- ★ Requires no damage, etc

## 2.4 Machine Structure





**7 inch screen size:**

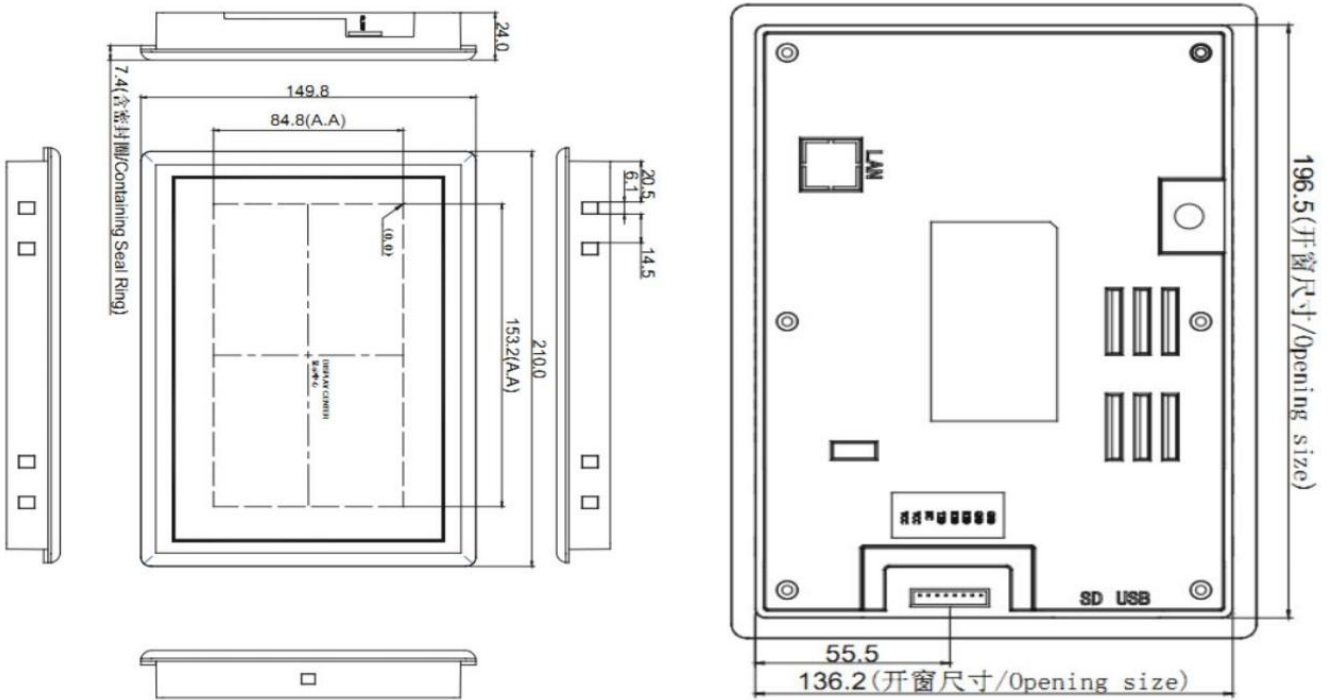

Overall dimension of cleaning gun:

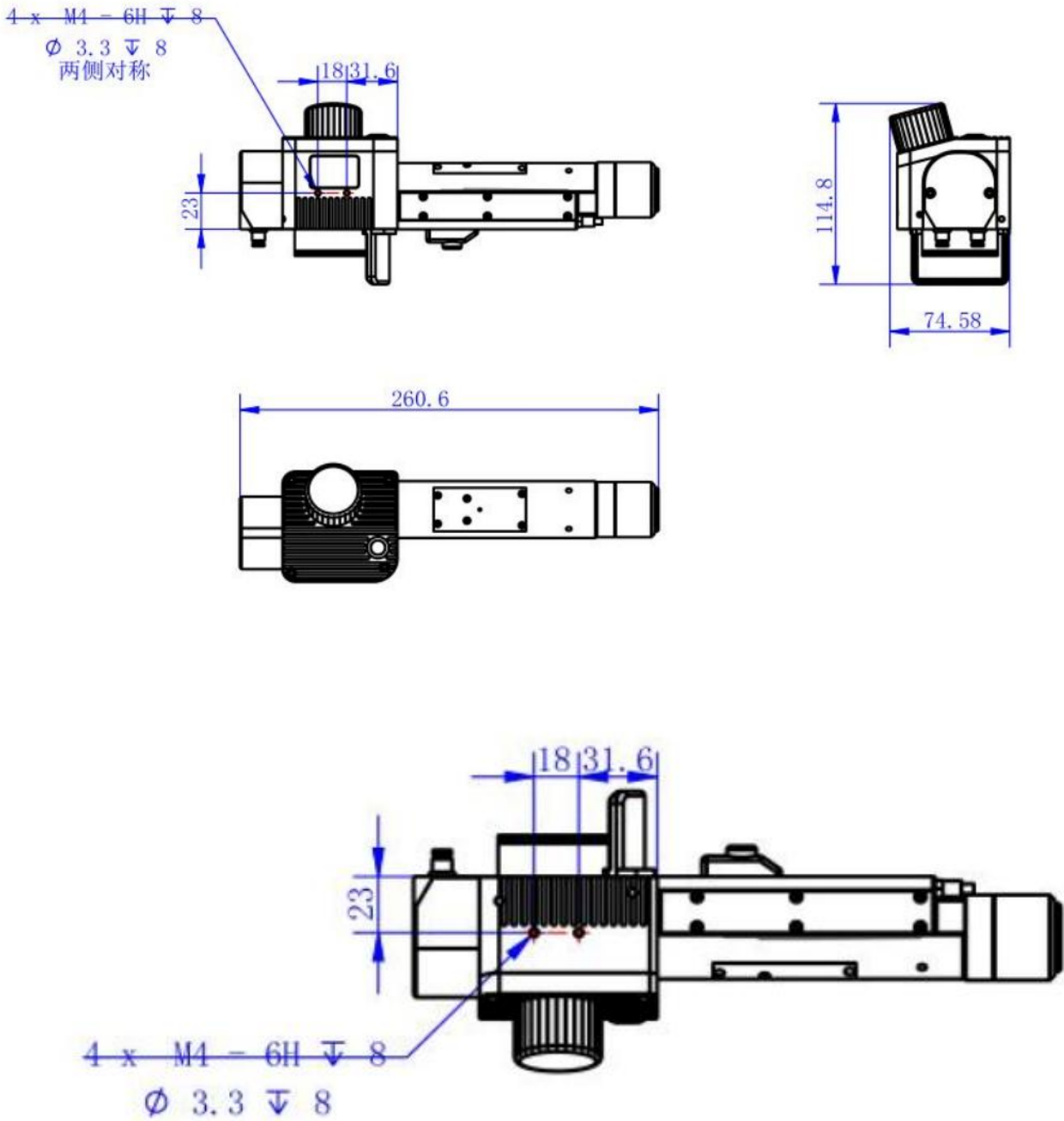

## 2.5 Packing List

# Packing list



**MACHINE**



**Power Cable**



**Protective Glasses**



**Protective Lens**



**Non-woven Fabric**



**Protective Gloves**

### 3. Technical Parameters

Name	Parameter
Laser power	500W
Laser source brand	JPT
Voltage	AC 100-120V/ AC 200-240V
Total power	2000W
Cooling methods	Air cooled ( water cooled optional)
Laser working mode	Pulsed
Fiber cable length	10M
Laser gun model	DHCP50-Pro
Light beam	Single mode Gaussian light/ Multi-mode flat-top light
Scanning speed	≤30000mm/s
Optical interface	QBH
Wavelength range	1030nm-1090nm
Field lens	M39*1 F254 (F160/F254/F300 optional)
Field lens protective lens	D43*2
Collimating lens	D17 F60
Oscillation frequency	≤200Hz
Cleaning efficiency	≤5 m <sup>2</sup> /h
Scan range	≤100mm@F160 ≤120mm@F254 ≤200mm@F300
Communication port	RS232
Effective aperture	φ 12
Cleaning type( 8 modes)	
Working Environment temperature	10~40℃
Packing Size:	74*73*46cm
Packing Weight	61.4KG

## 4. Operation Steps

### 4.1 Unpacking Inspection

Unpack and check whether the machine is in good condition. Check whether any accessories are missing by comparing them with the accessories list on the packing list. If any accessories are missing, please take a photo and contact the relevant after-sales personnel.

## 4.2 Machine Installation

First connect the power cable. It is recommended to connect an air compressor before use the machine. The air compressor can effectively prevent smoke from contaminating the lens, thereby increasing the service life of the machine. **This product does not come with an air compressor, so the users need to prepare one themselves.** It is recommended that the air compressor specification power is greater than or equal to 750W, air volume is greater than or equal to 15L, and mpa is greater than or equal to 0.2.



**Note:** When your air compressor pipe size is 6mm, then press the blue part on the meter and pull out the transparent pipe, insert your air compressor pipe directly. If your air compressor pipe size is 8mm, then connect your air compressor to the 8mm port directly (refer to following picture). After air compressor connected and turn on, the meter will run to 0.2Mpa automatically (this is what we require and set up before delivery).



### 4.3 Power On

- Step 1: Turn right the laser switch, to enter the “Swing Cleaning System”;
- Step 2: Click “Cleaning”;
- Step 3: Input password “1”;
- Step 4: Click “Sway” and “Laser”, machine is ready to work.
- Step 5: Press the dual red light button on the cleaning head to turn on the red light focus function;
- Step 6: Single click the laser switch on cleaning head to display the red light, move cleaning head up and down till the 2 red dots overlapping into 1;
- Step 7: Double click the laser switch on cleaning head to start cleaning.

**Step 1:**



**Step 2:** Click “Cleaning”

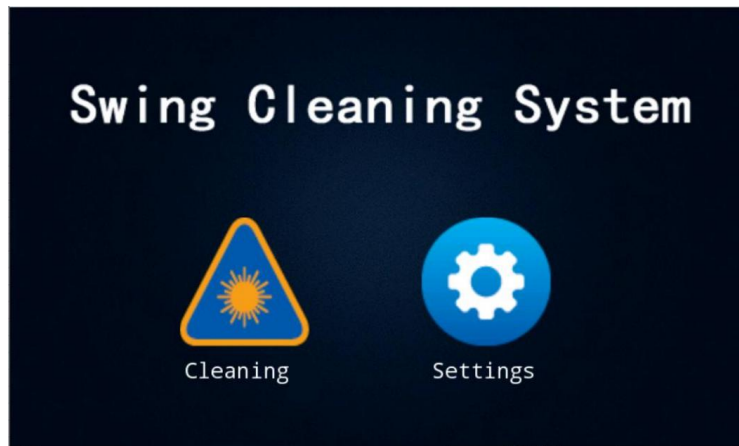

**Step 3:** Input password “1”

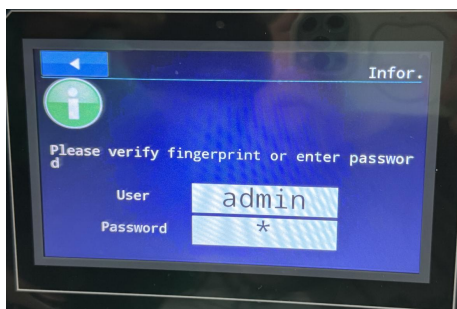

**Step 4:** Click “Sway” and “Laser”, machine is ready to run.

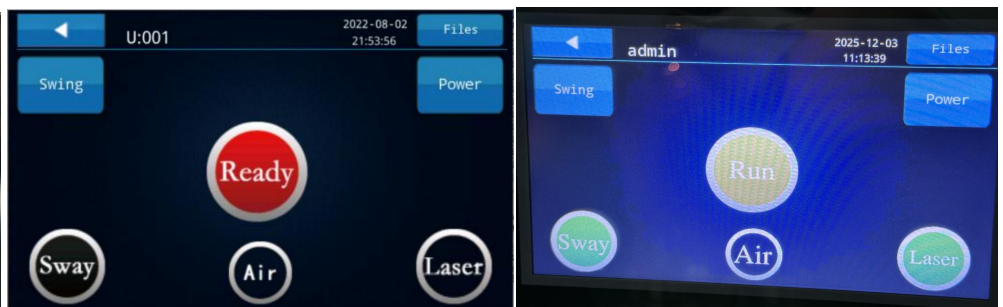

**Note: “Air” button is for Air blowing.**

Step 5: Press the dual red light button on the cleaning head to turn on the red light focus function;

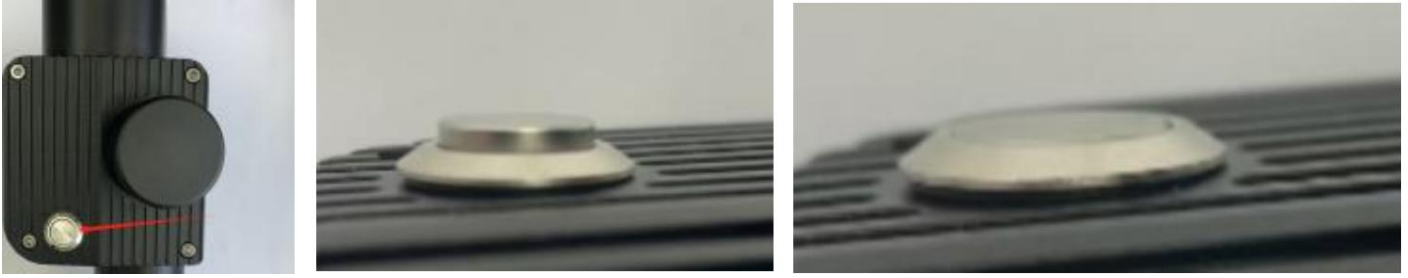

Step 6: Single click the laser switch on cleaning head to display the red light, move cleaning head up and down till the 2 red dots overlapping into 1 , this position is the best focus(**this distance is about 300 mm for F254 field lens**).



Step 7: Double click the laser switch on cleaning head to start cleaning.

**Note:** During the use of the laser, please conduct dust collection / air blowing, otherwise the raised dust will cause damage to the field lens!!!

#### 4.4 Parameter Settings

If the cleaning effect does not meet your requirements, you can also set these parameters as follow:

Step 1: Click "Cleaning";

Step 2: Click "Swing";

Step 3: Choose the "Swing type" you want and set up corresponding parameters on the right, there are total 8 kinds of swing types optional.

Step 4: Click "Power" to set up corresponding parameters.

Step 5: Start to clean.

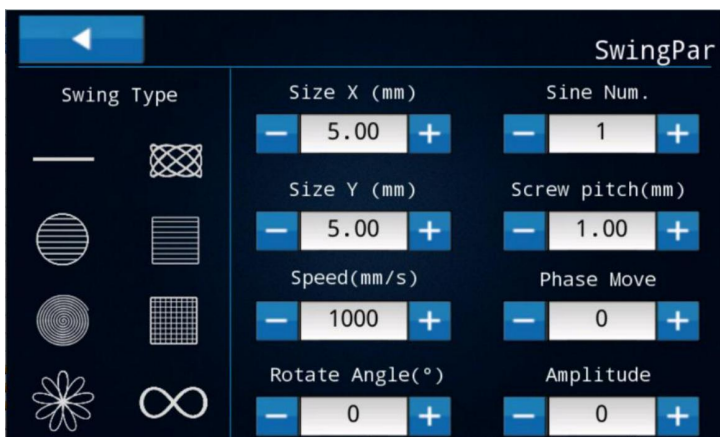
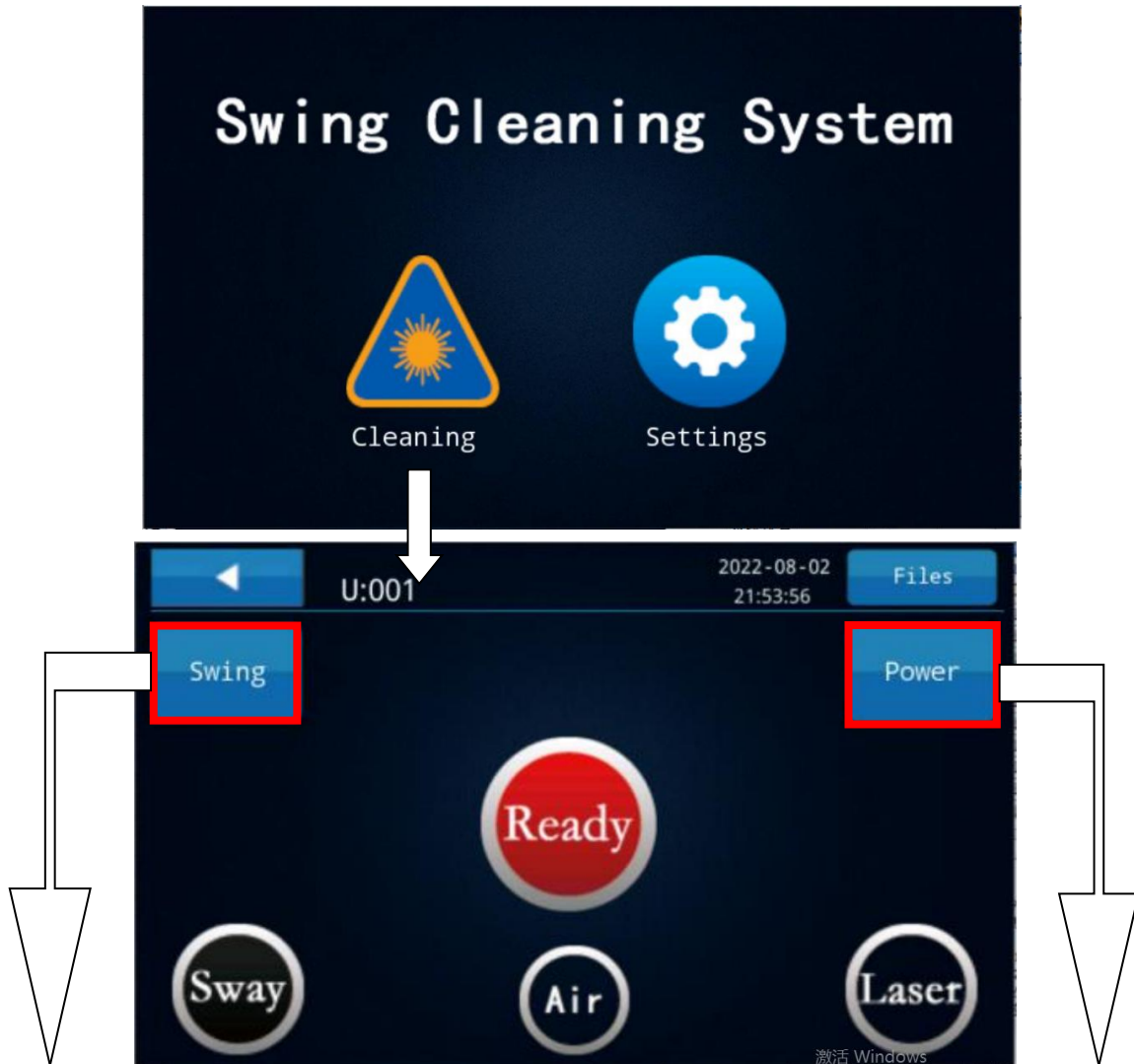

- Scanning width X:** the width of the scanning track of the cleaning head, 0.01~350.00mm (field lens limit)
- Scanning width Y:** the width of the scanning track of the cleaning head, 0.01~350.00mm (field lens limit)
- Scanning speed:** the speed of the cleaning head scanning track, 0~60000 mm/s (different tracks have different speed limits)
- Fill type:** type of ellipse fill and rectangle fill line

**Filling interval:** the interval between filling lines. The denser the filling, the better the cleaning effect, but the lower the efficiency.

**Fill angle:** fill line tilt angle, which can be set in conjunction with the "Rotation angle" parameter.

**Rotation angle:** the overall rotation angle of the scanned drawing (excluding the fill line angle).

**Phase shift:** the phase shift speed of the sine.

**Sine series:** the density series of sine wave line.

**Power:** control the output power of the laser from 0 to 100%.

**Duty cycle:** compared with laser switching light controlled by pulse mode (effective for continuous laser) .

**Frequency:** for continuous laser, it is used in combination with the duty ratio. When the duty ratio is 100%, this parameter does not work. For pulse laser, this parameter is set according to the laser power reduction frequency parameter table.

**Pulse width:** the pulse laser supports this parameter to control the pulse width of the laser. This parameter is set according to the laser power reduction frequency parameter table.

**Air blowing in advance:** the advance time of the air brake relative to the opening time.

**Delayed air closing:** the delay time of the air brake relative to the light closing.

In the [ Files ] page, you can set up cleaning parameters for different cleaning works and save the files to use next time for the same cleaning works.

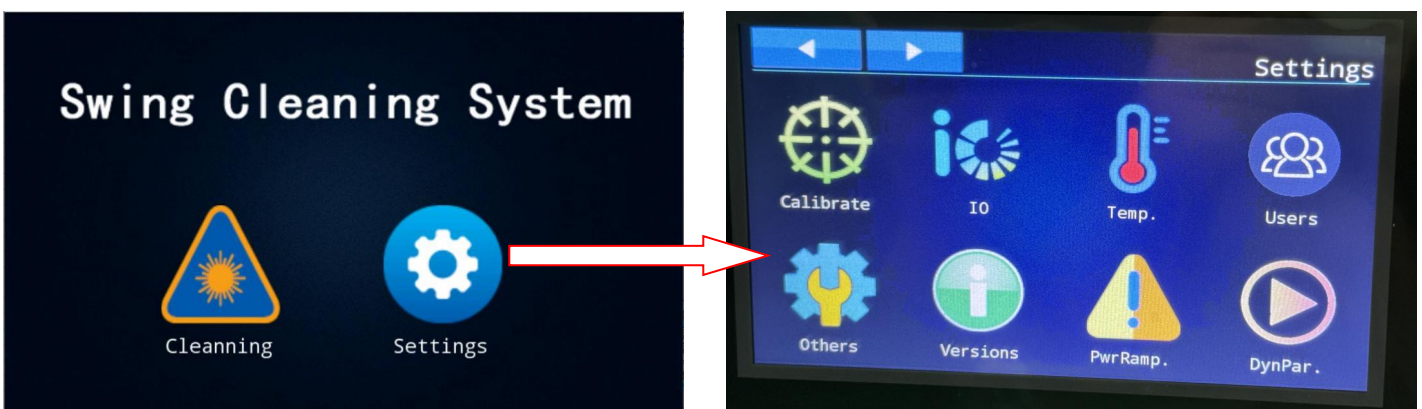

In [Calibrate] page, Click Column after LensType to choose lens type.

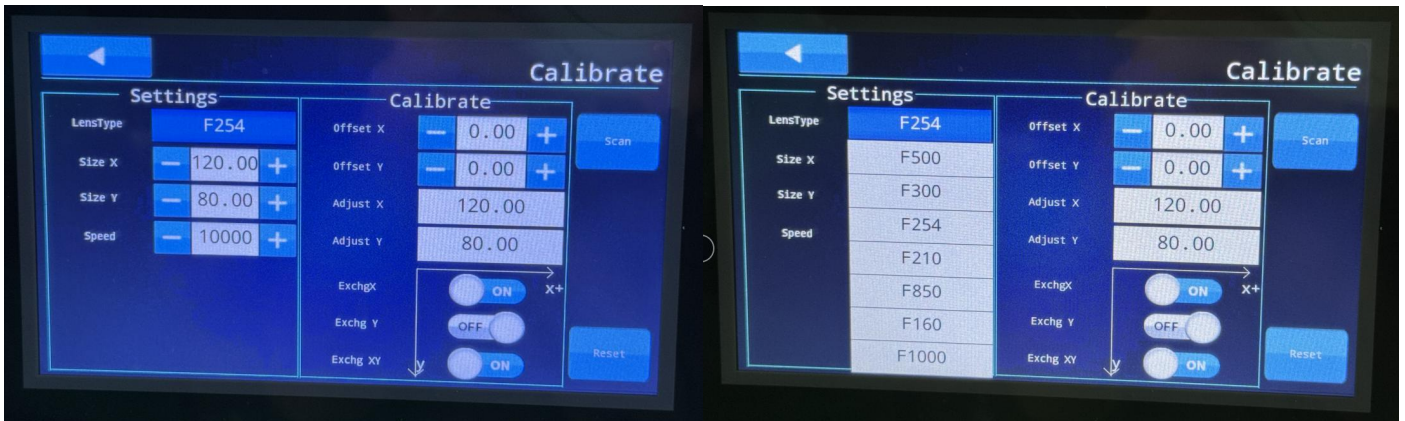

In **[Users]** page, you can create an operator account: Main page ->Settings ->Default password "6" ->Users ->Set "User type", "User name", "Password" and "Fingerprint registration" in order to complete user creation. (The system has established an account: the admin password is '1')

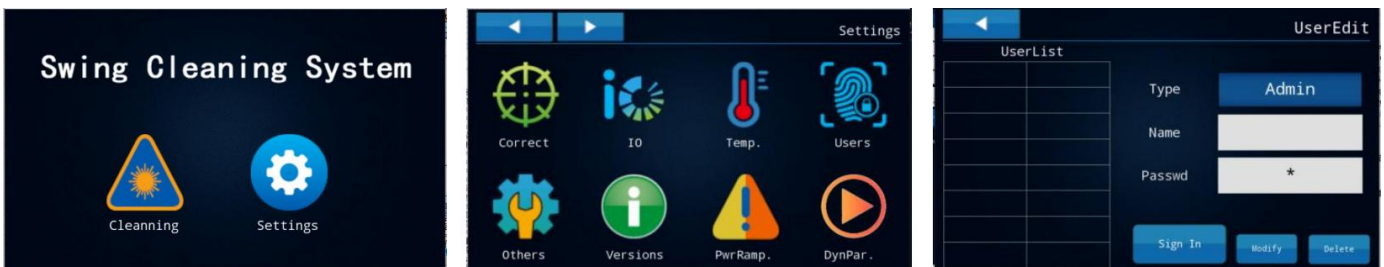

In **[Others]** interface to set up Language and Factory reset

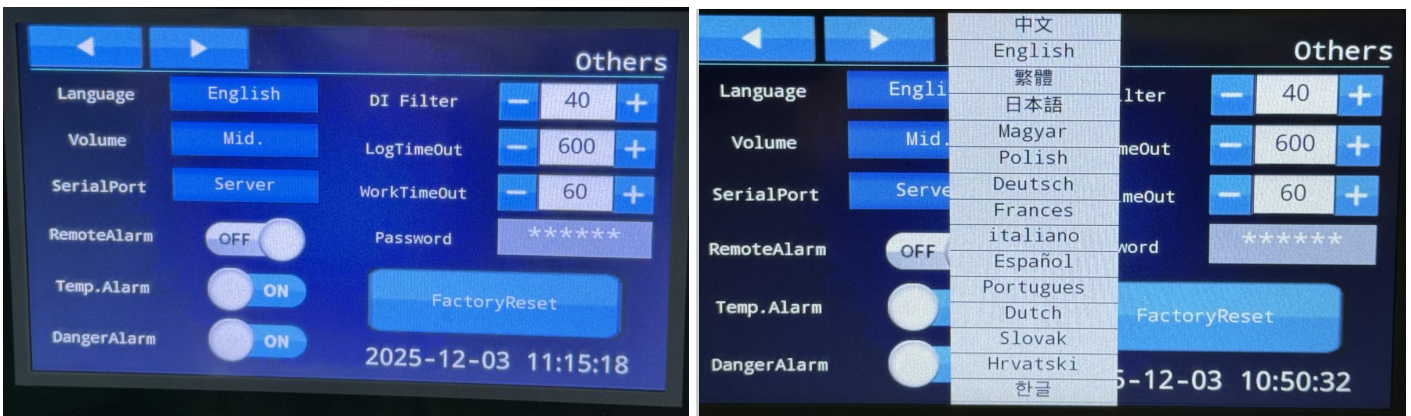

## 4.5 End Operation

After cleaning is completed, single-click the laser head switch button to stop the laser emission, then click the **[Laser]** button first and then **[Sway]** on the following interface, and finally turn off the laser switch on the machine and disconnect the power supply.



## 5. Maintenance

5.1 Regular cleaning: Keep the surface of the device clean to prevent dust accumulation.

5.2 Optical lens cleaning: Clean the laser lens and protective lens regularly to avoid contamination that may affect the cleaning effect.

The operation methods and precautions of lens cleaning:

Tools: dust-free gloves or dust-free finger cots, dust-free wiping cotton swabs, Anhydrous ethanol( $\geq 99.9\%$ ), and gas tank filled with dry and pure compressed air.

Spray anhydrous ethanol on the dust-free wiping cotton swab, place the lens directly in front of your eyes, gently pinch the side edge of the lens with your left thumb and index finger, hold the dust-free wiping cotton swab in your right hand, and gently wipe the front and back of the lens from bottom to top or from left to right in a single direction (do not wipe back and forth to avoid secondary contamination of the lens) and blow the surface of the lens with gas tank to confirm that there is no foreign matter on the surface of the lens after cleaning.



Note: All replacement parts are assembled in a dust-free workshop. Except for the first protective lens at the front end, other modules are prohibited from being disassembled in principle. If you must check the collimating lens, focusing lens, and galvanometer lens, please place the product in a clean environment for disassembly.

## 6. Troubleshooting and Solutions

### **No laser emission:**

Check whether the power supply and laser source well connected;

Check whether the machine voltage is consistent with the input voltage.

Check whether the machine is in the state of allowing light emission (after [Ready to clean] button clicked) and double-click the laser head switch button. For details, please refer to 4.3 power-on steps.

### **Poor cleaning effect:**

Adjust parameters such as laser power and scanning speed, or check whether the lens is clean.

Equipment overheating:

Check whether the cooling system is working properly.

Others:

You can also contact the corresponding after-sales service personnel directly for related questions.

## 7. After-sales Statement

**Warranty period:** The machine with a warranty of 12 months from the date of purchasement.

**Technical support:** We provide free technical support whole lifetime. Any questions please contact the corresponding after-sales service department.

**Repair service:** Free repair during the warranty period, and appropriate fees will be charged out of the warranty.

**Warranty range:** We provide warranty services for products with defects caused by materials or production processes during the warranty period, and guarantee that the products meet the relevant quality and specification requirements mentioned in the document under normal use.

We provide repair or replacement services for the machines that fail due to materials or production processes during the warranty period. After repair or replacement , the machine still hold the remaining warranty period.

### **We do not provide warranty for following situations:**

(1) Any tampering, opening, disassembly or modification on machines by personnel without the permission of our company;

(2) Damages caused by improper use, negligence or accident;

(3) Operation beyond the scope of machine specifications and technical requirements;

(4) Indirect damage to the laser source due to failure of user's software or interface;

(5) Use due to improper installation, maintenance or other abnormal operating conditions not included in this manual;

(6) Consumables are not covered by the warranty.

Customers are responsible for understanding the above information and operating in accordance with the user manual, otherwise the failure caused will not be covered by the warranty.

**Important:**

- ◎ Within warranty, customers must provide feedback within 30 days of discovering the fault.
- ◎ Shenzhen Scotle Technology Group Ltd. does not grant any third party or individual the right to repair or replace our products.
- ◎ To protect your rights, please be sure to contact the relevant after-sales department of our company as soon as possible after discovering the fault and apply for product repair or replacement service. If you need to return the product, please pack it in matching packages after authorization by our company and then return it to the place designated by our company.
- ◎ When any damage is found after receiving the product, you must keep the proof document so that we can claim rights from the transporter.
- ◎ Please do not send any product back to our company or any warehouse address without communication and confirmation.
- ◎ If the product is not within the warranty period or warranty scope, users need to pay the product repair costs.